

# OnSet<sup>7</sup>

News, Facts and Professional Solutions for Thermal Analysis

## In this edition:

### Page 3:

The MMC 274 *Nexus*<sup>®</sup> Multi Module Calorimeter

### Page 6:

Tips and Tricks: Determination of the specific heat by means of LFA

### Page 8:

The new TMA 402 *Hyperion*<sup>®</sup>  
 Introducing the latest addition to the NETZSCH instrument family

### Page 10:

Temperature-dependent measurements of the specific evaporation enthalpy by means of DSC

### Page 12:

**PRECISE PRACTICE**  
 Influence of the heating and cooling rates on the DSC measurement result

### Page 14:

**Faster – Hotter – More Flexible**  
 The 400 series instrument platform gets new 2400°C tungsten and high-speed furnaces

### Page 16:

Events

## Innovative Solutions for the Products of Tomorrow

Rolf Preuß, NGB Marketing Director



As varied as they may appear, fields like nanotechnology, insulation materials, photovoltaics, thermo-electrics, composites, and wind power generation all have one thing in common. From the development concept to the finished product and on through the end of the service life, the properties of the materials used must be known with precision. In conducting research for such fields, the interaction of a variety of materials is investigated.

- What combination yields the perfect product?
- How do results vary under arctic or tropical conditions?
- How do load changes influence the service life?

Without comprehensive knowledge of the thermal and thermophysical properties of the materials employed, these questions cannot be answered in a satisfactory manner.

Leading Thermal Analysis.



## Editorial

Dear Reader:

The Analyzing & Testing Business Unit has been taking advantage of recent months and years to improve our positioning in certain areas and to continue enhancing services for our customers. In the process, we have ascertained that many companies and research facilities have been relying more and more on the expertise of NETZSCH and the quality of our products. This was certainly part of the reason that our 2010 business year, which we closed on June 30<sup>th</sup>, had turned out to be such a successful one. Our incoming orders and orders at hand have now reach record levels and are already significantly higher than they had been immediately prior to the economic crisis. On that note, we wish to extend our warm thanks for the trust you have shown in our company.

Moving forward, we are reinvesting the fruits of these achievements to provide you with even better support and products for your day-to-day work. In recent months, we have launched even more innovative solutions onto the market, which we will be presenting to you in this edition of the OnSet.

We are especially proud of the new TMA 402 **F1/F3 Hyperion**<sup>®</sup>. Its high force capabilities, exact force control and force modulation allow this instrument to provide measuring possibilities far beyond the capacity of any previous generation of instruments for thermoanalytical analysis.

On par with the new TMA is the MMC 274 *Nexus*<sup>®</sup>. Its development has opened completely new application fields for adiabatic calorimetry. For those who were having trouble deciding between a Dynamic Scanning Calorimeter and a classical calorimeter, we now offer this instrument combining both methods in one apparatus.

In addition to the introduction of these new instruments, we have again compiled some tips and tricks for you, as well as more information on the optimal handling of NETZSCH instruments. We will also be introducing you to certain special extensions for NETZSCH instruments, such as the new high-speed furnace for our DSCs and STAs.

We are particularly pleased to present the article contributed by our customers, Prof. Jacob and Mr. Schuhmann at the Georg-Simon-Ohm University in Nuremberg, demonstrating how evaporation enthalpies can be measured precisely with a conventional DSC.

All in all, we hope that you will find some inspiration for your-to-day work in this new edition of the OnSet.

Dr. Jürgen Blumm, Managing Director, Sales, Application & Marketing

Continued from Page 1

### NETZSCH helps you find the answers

Researchers all over the world are working with NETZSCH analytical instruments to systematically develop materials.

Such developments are aimed at improving material properties and thereby increasing efficiency. In some cases, this can open up entirely new application fields, such as the conversion of waste heat from power plants or automobiles into electrical power.

In Europe, private households account for approximately 30% of total energy consumption. A good portion of this is used for heating rooms. The European Union has energy saving objectives which can only be achieved if the amount of heat required in new buildings and existing housing is reduced considerably. Innovative insulation materials are one answer, and NETZSCH instruments are employed in developing them. Leading companies use the HFM 436 Heat Flow Meter, for example, in the development of new PUR foams or in quality assurance for EPS, and the DIL 402 C Dilatometer is used to investigate the thermal expansion of insulation materials.

NETZSCH Analyzing & Testing is at home in any markets where precise knowledge about materials is essential. We are proud to be supporting efforts in research, development, manufacturing, quality assurance across the globe with our innovative systems solutions and applications know-how.

We look forward to assisting in your new endeavors as well!

# The MMC 274 Nexus® Multi Module Calorimeter

Dr. Ekkehard Füglein, NGB Sales & Applications Support



Fig. 1. MMC 274 Nexus® Base unit with two additional calorimeter modules

In the field of calorimetry, there are numerous alternatives and measurement methods specifically tailored to individual issues. Just as numerous are the different measurement setups and instruments employed. What they all have in common is the quantification of heat, heat flow or heat exchange between the sample to be investigated and the environment. The mode of operation for each of the four most common calorimeter types will be briefly explained here, and the exceptional versatility of the MMC 274 Nexus® will then be illustrated.

**Reaction calorimeters** are tailored to the investigation of liquid reaction mixtures with volumes of several hundred milliliters. The main focus here is the homogeneous mixing, stirring or dosing of solutions. The resulting heat of reaction is generally absorbed by a cooling agent in a double-walled glass vessel. The temperature difference occurring in the cooling agent during the course

of the reaction is proportional to the heat of reaction produced. Hence, an optimum heat exchange between the reaction mixture and the surrounding cooling jacket is decisively important, while the development of higher pressures during the reaction can cause problems for the calorimeter.

**Combustion calorimeters** (or bomb calorimeters), in contrast, consist of very robust sample vessels in which a certain amount of organic materials (e.g. carbon) is ignited by means of an electric device. The oxygen required for combustion is introduced in surplus prior to the reaction by charging the reaction vessel with the corresponding excess pressure in oxygen. Also in this case, the heat created during the reaction is released to the surrounding medium and the temperature increase of that medium is a measure for the heat created. The calorific values of different fuels can thus be determined. However, materials cannot be exchanged in this system.

**Dynamic calorimeters**, such as the popular DSC instruments (Differential Scanning Calorimetry), use only very small sample amounts (typically 5 to 10 mg) and can therefore be operated at faster heating and cooling rates. It is only by means of such small sample amounts that rates of up to 200 K/min can be realized. Temperature programs with several heating and cooling segments are especially common in polymer analysis, as important conclusions on the thermal and mechanical history (e.g. the degree of crystallization) of polymer samples can be drawn.

**Adiabatic calorimeters** (ARC: "Accelerating Rate Calorimeter") are specially designed to investigate "worst-case scenarios". The "worst case" for a reaction reactor occurs when the heat released during the reaction cannot be dissipated to the environment sufficiently or perhaps at all. Adiabatic calorimeters are therefore designed to eliminate heat exchange with the environment. The heat remaining in the reaction vessel leads to a steady temperature increase (self-heating) which can, in turn, result in an acceleration of the reaction and finally, a sudden decomposition or explosion of the reaction mixture.

The very different operating modes of the various calorimeters make it clear that a wide range of requirements exists with regard to sample volume, temperature supply, temperature control and heat exchange between the sample vessel and the environment (and therefore the actual detection of the measuring signals).

Although there are some combustion and reaction calorimeters offering an "adiabatic mode", a glance at the design of those two calorimeter types

Leading Thermal Analysis.

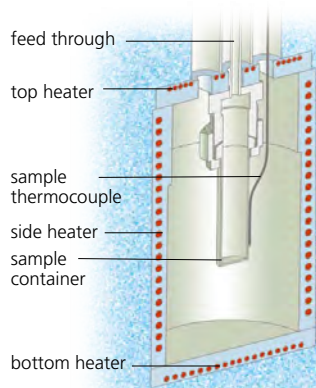

Fig. 2a. Cross-section of the MMC 274 Nexus® ARC module

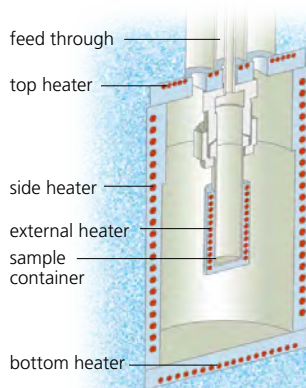

Fig. 2b. Cross-section of the MMC 274 Nexus® external heater module

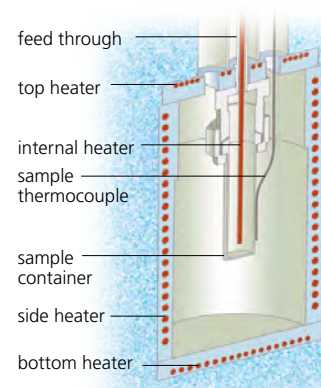

Fig. 2c. Cross-section of the MMC 274 Nexus® VariPhi™ module

will quickly lead one to conclude that the quality of information yielded would certainly be inferior to that of true adiabatic calorimeters. Then again, some of these calorimeters can also be operated in a dynamic mode. Still, it soon becomes apparent that no fast heating or cooling rates can be realized due to the large sample volumes or very heavy sample vessels. Therefore, in the past it had not been possible to use a single calorimeter for different measurements tasks – or at best, only to a limited extent. The modular design of the MMC 274 Nexus® has resolved this issue by combining the main advantages of the DSC and adiabatic calorimetry methods.

A calorimeter capable of handling a large variety of measuring tasks has finally been brought to market in the MMC 274 Nexus® multi module calorimeter. Isothermal measurements, adiabatic investigations or measurements at a constant heating rate (scanning mode) are all possible. The base unit containing the MMC electronics can be equipped with easily exchanged measurement modules (figure 2).

#### ARC Module:

- What is the maximum ratio of the reactor volume to the cooling jacket?
- What product quantity can be produced in a reactor per hour at a constant temperature?
- By how many degrees Celsius does the reactor temperature increase when the cooling circuit suddenly fails ( $T_{ad}$ : adiabatic temperature increase)?
- How much time does it take from the start of a thermal runaway until the maximum reaction rate is reached ( $TMR_{ad}$ : “adiabatic time to maximum rate”)?

Questions like these can be answered with the help of adiabatic calorimetry. That is why investigations of samples or reactor mixtures in an adiabatic environment are part of the basic principles in process safety.

Figure 2a shows the MMC with a cross-section of the ARC module employed for adiabatic measurements. The cylindrical sample vessel is inserted into the calorimeter environment in such a way that only the feedings for pressure and

temperature measurement are present at the upper opening next to the mounting in the calorimeter. The lateral walls, bottom, and lid of the calorimeter environment can be heated in order to carry out tracking of the sample temperature.

During the measurement, the sample temperature is continuously measured and, if the temperature increases, the ambient temperature of the calorimeter is similarly controlled. As a result, all of the heat released into the system during a chemical reaction remains in the system and, in turn, accelerates the reaction process. This generally leads to a self-accelerating reaction which, in the worst case, can result in an explosion. This would correspond to the worst-case scenario in a production plant or reactor. The sizing of the reactor volume, the dosing speed of the individual reacting agents and the capacity of the cooling device are heavily dependent on these simulation experiments. The results of the evaluation of  $\Delta T_{ad}$  and  $TMR_{ad}$  from a HWS™ measurement for a 20% DTBP solution in toluene are depicted in figure 3.

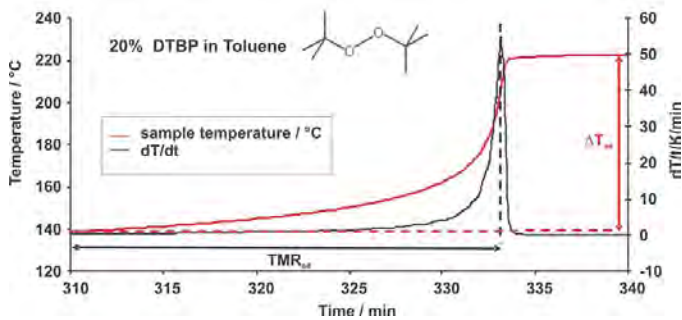

Fig. 3. Determination of  $TMR_{ad}$  and  $\Delta T_{ad}$  of a 20% solution of DTBP in toluene

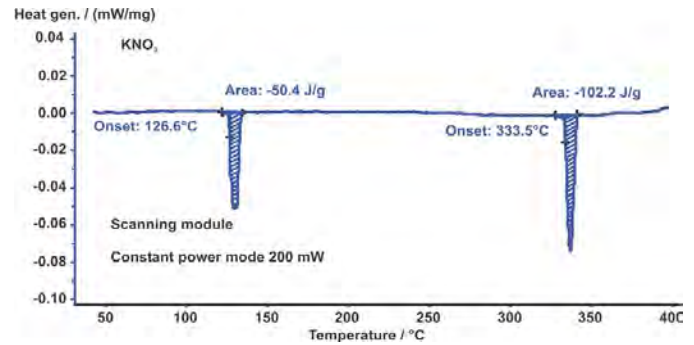

Fig. 4. DSC-like analysis of the phase transitions of 1.9 g of  $KNO_3$  structural change at 127°C, melting at 334°C

### External heater module:

Figure 2b shows a cross-section of the "external heater module". This setup, where the sample vessel is surrounded directly by the heater, allows DSC-like measurements to be carried out at a constant heating rate. As with a standard DSC instrument, this makes it possible to record endothermal and exothermal sample events, unlike an Accelerating Rate Calorimeter. The sample can be heated not only at a constant heating rate, but also under a constant load. The structural (endothermal) transitions of  $KNO_3$  are depicted in figure 4.

### VariPhi™:

Finally, the cross-section in figure 2c shows the measurement setup with an internal heater, the VariPhi™. This patented heater makes it possible to compensate for heat lost via the vessel wall when the heat of reaction is released. Only in this way can the true ratios of a large reactor of several cubic meters in volume be depicted in analytical scale (variable phi factor). In addition, the specific heat capacities of samples can be determined directly with the VariPhi™; the results for water, toluene and silicone oil are summarized in figure 5.

These three examples demonstrate that the MMC 274 Nexus® is capable not only of adiabatic measurements, but also of DSC-like measurements and the direct determination of specific heat.

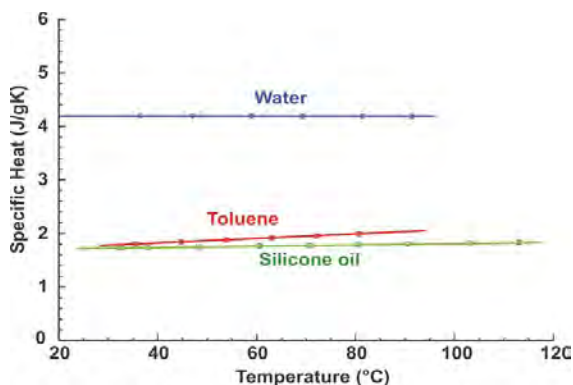

Fig. 5. Direct comparison of the specific heat capacities of water, toluene and silicone oil



Dr. Ekkehard Füglein

### The Author:

Dr. Ekkehard Füglein studied chemistry at the Julius-Maximilian University in Würzburg and received his Ph.D. specializing in Inorganic Chemistry and Materials Chemistry. Since 2002, he has been employed at NETZSCH-Gerätebau GmbH in the field of applications consultancy for thermal analysis.

# Tips and Tricks

## Determination of the Specific Heat by Means of LFA

Dr. Gabriele Kaiser, Head of NGB Applications Laboratory

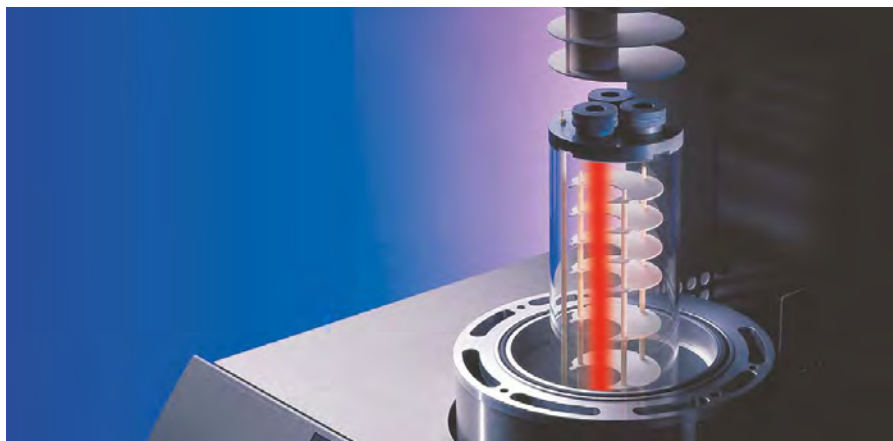

top surface of the sample (figure 1 shows the theoretical profile) is relatively low and normally amounts to less than 1 K. To calculate the thermal diffusivity, the half time  $t_{1/2}$  (time corresponding to half the step height) is used. The total temperature increase (step height) can be used to determine the specific heat. It is indirectly proportional to the heat capacity of the sample (fig. 1).

The method for determining the specific heat with LFA measurements is described in detail in ASTM E 1461-07, Annex X2. One of the main requirements for this standard is the use of a reference material with a known specific heat value. The  $c_p$  of an unknown material can be calculated by comparing the signal heights between sample and reference (see formula).

As of yet, there are no certified standard materials of proper size (12.7 mm in diameter) available for this purpose on the market. The ASTM standard therefore lists several industry-accepted reference materials for studying thermal diffusivity in Annex X3, such as electrolytic iron and POCO graphite (AXM-5QA), which are distributed by NIST as thermal conductivity standards.

NETZSCH offers you the following reference materials, tailored to various temperature and thermal diffusivity ranges: POCO graphite,  $\text{Al}_2\text{O}_3$ , Pyroceram 9606, electrolytic iron, stainless steel (SRM 1461), aluminum, Pyrex and copper.

For accurate comparability of the absolute step heights (temperature increases on the sample surface), identical experimental parameters for sample and reference measurements are recommended.

After discussing the basics of specific heat and the precise determination of  $c_p$  by means of Differential Scanning Calorimetry (DSC) in the last two issues of OnSet (OnSet<sup>5</sup> and OnSet<sup>6</sup>, respectively), this final article covers the determination of specific heat by means of the laser or light flash method (LFA).

In this method, the bottom surface of a sample is heated by a light flash (lamp) or a short laser pulse and the resulting temperature rise on the top surface of the sample is measured using an infrared detector.

This method was introduced in 1961 by Parker et al. and was initially limited to isotropic materials and

adiabatic conditions, i.e. there was no heat exchange with the environment.

Over the years, however, mathematic models for adjusting experimental data have been refined and factors like heat loss, pulse length effects, etc. have been integrated. The laser or light flash analysis has thus become a worldwide method of choice for determination of thermal diffusivity and conductivity.

It is a discontinuous measuring technique which heats to defined temperature steps and then holds the temperature constant. After temperature stabilization, three to five measurements are generally carried out. The temperature increase on the

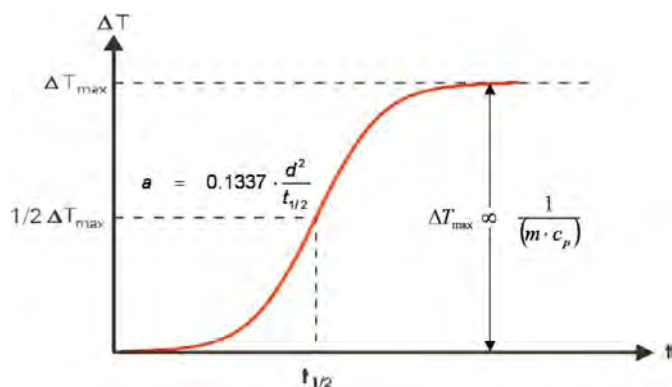

Fig. 1. Theoretical LFA signal

Special attention must be paid to the emissivity of the surface as well as to the area to be analyzed. Consistent emissivity can be guaranteed by coating as uniformly as possible with graphite. The area to be analyzed corresponds to the diameter of the opening in the cover plate. Even if the sizes or geometries of the sample and reference otherwise differ, the diameters of the cover plates must match.

For the LFA 447 *NanoFlash*<sup>®</sup>, the amount of space between the material surface and the detector must also be taken into consideration. If the sample is considerably thinner than the reference material, for example, the sample should be positioned accordingly higher by means of a ring or similar support.

As with  $c_p$  determination by means of DSC, it is advisable to carry out the

$$c_p^{\text{Sample}}(T) = \frac{T_{\infty}^{\text{Ref.}}}{T_{\infty}^{\text{Sample}}} \cdot \frac{Q^{\text{Sample}}}{Q^{\text{Ref.}}} \cdot \frac{V^{\text{Sample}}}{V^{\text{Ref.}}} \cdot \frac{\rho^{\text{Ref.}}}{\rho^{\text{Sample}}} \cdot \frac{D^{\text{Ref.}}}{D^{\text{Sample}}} \cdot \frac{d_{\text{Sample-Aperture}}^2}{d_{\text{Ref.-Aperture}}^2} \cdot c_p^{\text{Ref.}}(T)$$

sample and reference measurements either simultaneously or in immediate succession. For compact solids, a  $c_p$  accuracy of +/- 5-7% or better can be achieved (depending on the sample preparation). This method is not suitable for pastes, powders, liquids or inhomogeneous samples.

Figure 2 depicts the  $c_p$  data of stainless steel (standard reference material SRM 1461 for thermal conductivity) achieved with LFA measurements in comparison with the specific heat values resulting from a DSC investigation. The deviation of the data is considerably lower than the error bars indicated, which represent +/- 3%.

T: height of the detector signals  
Q: irradiated (laser) energy  
V: amplification factor  
 $\rho$ : density  
D: thickness of the sample or reference  
d: opening diameter

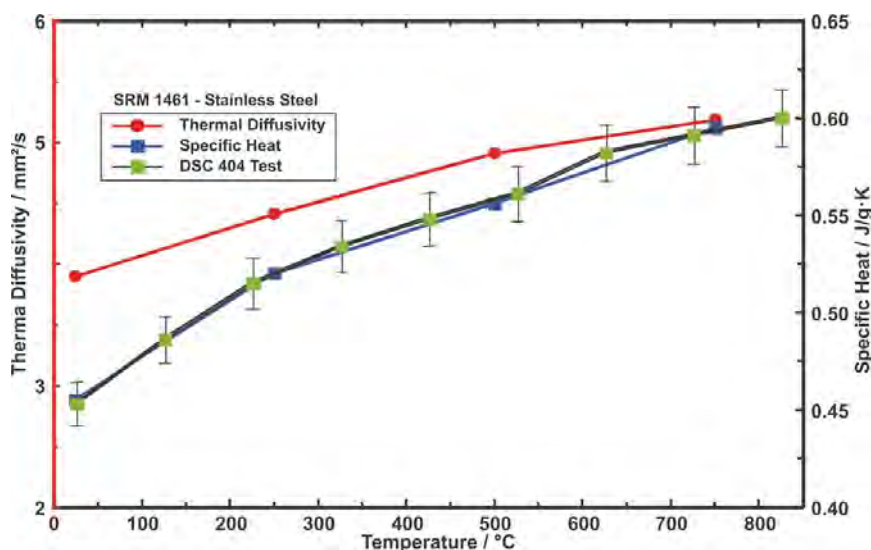
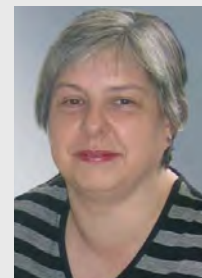

Fig. 2. Comparison of  $c_p$  data obtained with different methods (LFA and DSC)



Dr. Gabriele Kaiser

### The Author:

Dr. Gabriele Kaiser studied chemistry in Erlangen and started working at NETZSCH-Gerätebau after receiving her doctorate in physical chemistry in September 1991. As head of the training department, she has been responsible for the application training and consultation of customers, sales partners and co-workers. Since July 2008, she is head of the applications laboratory in Selb.

# The New TMA 402 *Hyperion*<sup>®</sup>

## Introducing the Latest Addition to the NETZSCH Instrument Family

Georg Stroch, NGB Development; Dr. Gabriele Kaiser, Head of NGB Applications Laboratory

In thermomechanical analysis (TMA), the change in sample expansion is measured in the vertical direction. In contrast to dilatometry, however, it is not only the temperature which is variable here, but the force operating on the sample as well. This allows testing on even fragile samples such as thin fibers. The length change resulting from a change in force also yields information on the elastic properties of a material.

The new TMA 402 *Hyperion*<sup>®</sup> is replacing our proven TMA 202 and TMA 402 combining their renowned precision and reliability with a number of improvements and new functions. The application range has been extended with temperatures now up to 1550°C. New standards have been

set, even with regard to force control. In the range from 1 mN up to a maximum force of 3 N, any desired value can be set via the software. Stepwise or linear load changes can also be programmed during ongoing measurements. The premium version of the TMA 402 **F1** also allows for continuous modulation of the force in

the form of saw-tooth, rectangular or sinusoidal functions with a frequency of up to 1 Hz. The actual force operating on the sample is continuously measured and recorded in order to enable precise analysis of the stress-strain behavior of the modulus of elasticity.

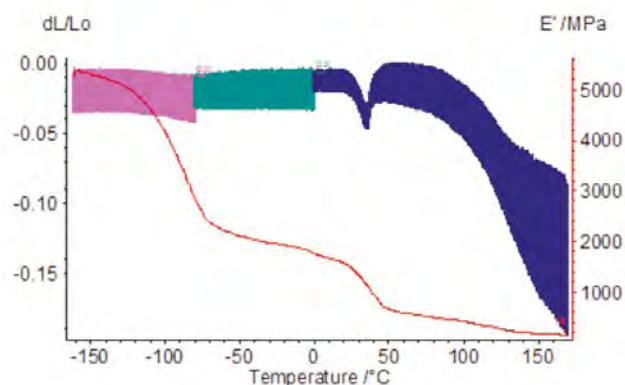

Fig. 2. Determination of the E modulus of PTFE by means of 3-point bending with modulated force



Fig. 1. TMA 402 *Hyperion*<sup>®</sup>

Great flexibility in the temperature range is achieved via the compatibility of the *Hyperion*<sup>®</sup> with the NETZSCH high-temperature instrument series. The furnace utilized can be changed depending on the application. For low-temperature measurements, a steel furnace with liquid nitrogen cooling is available, covering a temperature range of -150°C up to 1000°C. A furnace with an SiC heating element can alternatively be used, featuring a maximum temperature of up to 1550°C. The optimum double-hoist device allows furnace switching within seconds. Either furnace can also be employed for the STA 449 *Jupiter*<sup>®</sup> or DSC 404 *Pegasus*<sup>®</sup>.

Technical Data	TMA 402 F1	TMA 402 F3
Max. sample length	30 mm	30 mm
Measuring range	+ 2.5 mm	+ 2.5 mm
Dig. resolution (length)	0,125 nm	0,125 nm
Force range	0.001 N to 3 N in steps 0.2 mN (tension or pressure)	
Dig. resolution (force)	<0.01 mN	<0.01 mN
Modulation frequency	Up to 1 Hz	–
Final vacuum pressure	10 <sup>-4</sup> mbar	10 <sup>-2</sup> mbar
Gas connections	Protective gas, 2 purge gases	
Gas flow control	Digital Mass Flow Controllers	Control valves

With regard to sample geometries, the variety of sample holder systems allows for maximum flexibility. You can choose from the expansion, penetration, tension or 3-point bending mode. Depending on the temperature range, appropriate sample holders made of low-expansion fused silica or highly temperature-resistant aluminum oxide are available. Other accessories allow for investigation of powders, melts or immersion in liquids.

To analyze gaseous reaction products evolving upon heating, the TMA 402 *Hyperion*<sup>®</sup> can be coupled to a mass spectrometer and/or FTIR gas analyzer.

The *Hyperion*<sup>®</sup> is an extremely versatile instrument which can be employed for a great variety of measurement tasks – from determination of the elastic behavior of polymers to optimization of ceramic sintering processes.

### The Authors:



Georg Storch studied physics in Erlangen, Grenoble and Würzburg. He then joined the scientific staff at ZAE Bayern in Garching near Munich, where his work focused on heat storage in zeolites. During that time, he gained experience with self-built thermobalances. Since 2009, he has been on the development team at NETZSCH-Gerätebau.

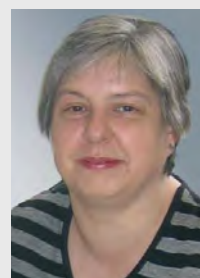

Dr. Gabriele Kaiser studied chemistry in Erlangen and started working at NETZSCH-Gerätebau after receiving her doctorate in physical chemistry in September 1991. As head of the training department, she has been responsible for the application training and consultation of customers, sales partners and co-workers. Since July 2008, she is head of the applications laboratory in Selb.

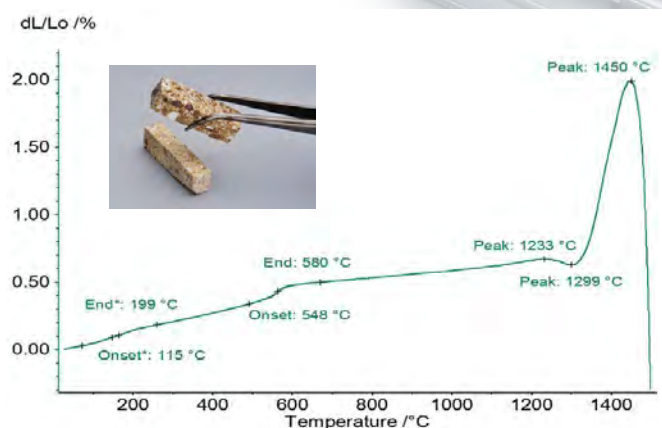

Fig. 3. Investigation of the expansion behavior of a refractory down to the softening point at 1450°C



Fig. 4. Some of the available sample carriers

# Temperature-Dependent Measurements of the Specific Evaporation Enthalpy by Means of DSC

Prof. Dr. Karl-Heinz Jacob, Physical Chemistry at the Georg-Simon-Ohm University in Nuremberg and Michael Schuhmann, Huhtamaki Deutschland GmbH & Co.KG, Forchheim

The specific evaporation enthalpy is an important parameter for the planning and operation of plants where liquids evaporate or condense. By definition, it is the heat quantity required for the isothermal evaporation of one gram of a liquid. For pure substances, this is derived from the molar evaporation enthalpy, which can be determined by means of vapor pressure measurements. For liquid mixtures, the specific evaporation enthalpy must generally be calculated. In ideal mixing systems, this is yielded by summation of the specific evaporation enthalpies of the individual components of the mixture, weighted by their mass fractions. However, the composition of a multi-component system must be known and, for more precise calculations, the interaction parameters as well. For complex liquid mixtures, this approach is not feasible. An example of a complex fluid is a fuel system; these may consist of several hundred components. It requires a great deal of effort to determine their exact compositions and the related interaction parameters.

In order to determine the specific evaporation enthalpy for such complex liquid systems, the NETZSCH DSC 204 *Phoenix*<sup>®</sup> was modified so as to be able to measure the specific evaporation enthalpy directly, with an accuracy of better than  $\pm 2\%$ .

## Measuring Principle

The basis of the technique is the DSC 204 *Phoenix*<sup>®</sup> which measures the endothermic heat flow of an evaporating sample. The liquid sample is injected directly into the sample crucible via a capillary, the end of which is tempered into the measuring chamber. A precise dosing system (dosing accuracy of approximately 1%) provides exact injection volumes. Since the DSC instrument does not

have to be opened for insertion of the sample, the sample crucible, the measuring chamber and the sample present in the capillary (see figure 1) will already have reached measuring temperature prior to the measurement. This ensures exclusive measurement of the isothermal evaporation enthalpy. During the measurement, nitrogen flows through the measuring chamber to suppress oxidation processes.

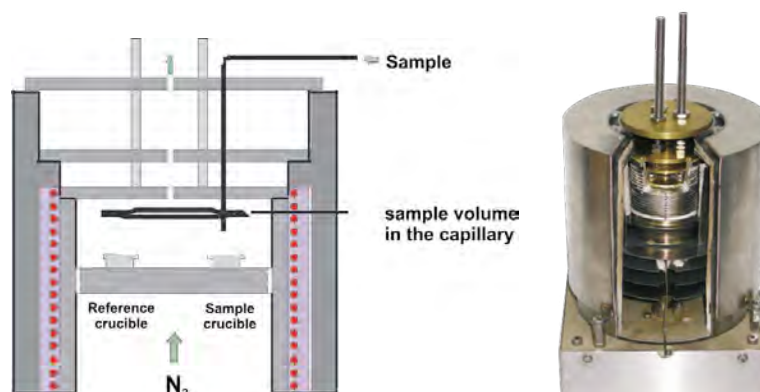

Fig. 1. Schematic representation of the modified measuring cell of a DSC 204 *Phoenix*<sup>®</sup>. Left. Diagram of a DSC measuring cell with inserted dosing head. Right. Cross-section of a DSC measuring cell with inserted measuring head.

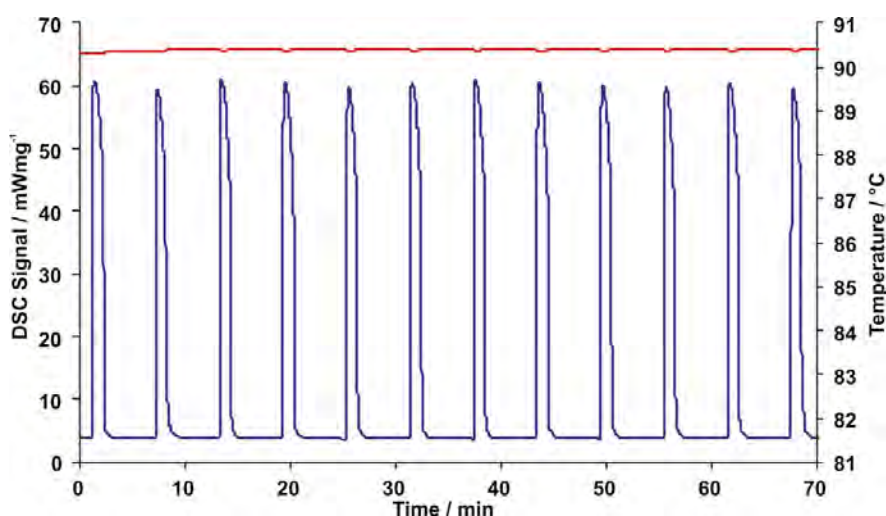

Fig. 2. Example of a DSC measurement with direct injection of n-octane at 90°C (red line: temperature of the measuring cell; blue line: heat flow)

**(1) Evaporation enthalpy: area under the heat flow signal**

$$\Delta_{\text{vap}} H_i = \int_{t_0}^t \dot{q} dt$$

$\dot{q}$	Recorded heat flow
$\Delta_{\text{vap}} H_i$	Evaporation enthalpy: integrated heat flow signal
$m$	Injected sample quantity
$n$	Number of measurements at one measuring temperature

**(2) Specific evaporation enthalpy**

$$\Delta_{\text{vap}} \bar{h} = \frac{1}{n} \sum \frac{\Delta_{\text{vap}} H_i}{m}$$

$\Delta_{\text{vap}} \bar{h}$	Average specific evaporation enthalpy for one measuring temperature
$\Delta_{\text{vap}} h(T)$	Specific evaporation enthalpy for one temperature

**(3) Watson equation**

$$\Delta_{\text{vap}} h(T) = \Delta_{\text{vap}} h_b \left( \frac{1 - \frac{T}{T_C}}{1 - \frac{T_b}{T_C}} \right)^{0,38}$$

$\Delta_{\text{vap}} h_b$	Specific evaporation enthalpy at the boiling temperature $T_b$
$T_b$	Boiling temperature
$T_C$	Critical temperature

**Experimental and Evaluation of the Measurement Results**

Once the required measuring temperature is constant, an automatic dispenser which is flange-mounted onto the DSC instrument injects the sample volume of approximately 20  $\mu\text{l}$  into the sample crucible by means of the capillary which is firmly installed in the dosing head. When the end of the DSC measuring peak is reached and the baseline is stable again, reinjection starts (see figure 2). At least six injections are carried out per measuring temperature. The injected mass is determined at the end of a measurement series by lifting the measuring head, while still "warm", from the DSC instrument, and injecting the adjusted sample quantity several times into an Eppendorf vial which is then reweighed.

The individual DSC measuring peaks (figure 2) are integrated by means of the *Proteus*<sup>®</sup> evaluation software (1). For determination of the evaporation enthalpies according to equation (2), the measured values for the injected mass are scaled, and six repetitive measurements are averaged.

**Calibration**

To verify the accuracy of the measurement method, the specific evaporation enthalpies  $\Delta_{\text{vap}} h$  of toluene, n-decane, n-hexadecane and other pure substances were measured as a function of temperature and compared with literature data and calculated data. Literature data is at 25°C and at the boiling temperature. For all other temperatures, the specific evaporation enthalpies can be

calculated using the Watson equation (3) or by means of process simulation programs such as ChemCAD<sup>®</sup>. The calibration measurements deviate by less than 2% from the specific vaporation enthalpies determined as function of temperature. Only when near the boiling temperature does the deviation significantly increase; this can be attributed to "evaporation" of the liquid from the sample volume in the capillary.

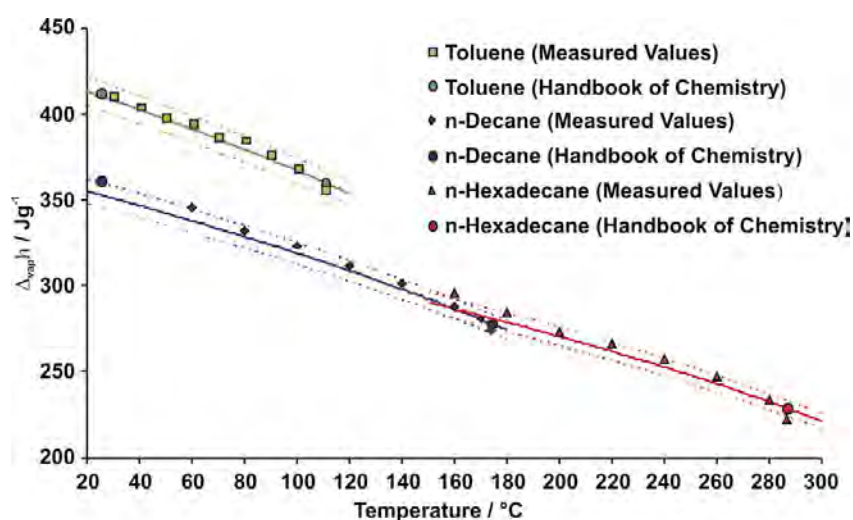

Fig. 3. Calibration results for toluene (green), n-decane (blue) and n-hexadecane (red) compared to the values from the Watson equation (solid lines) and literature values (red dots). All measurement values lie within a confidence level of  $\pm 2\%$ .

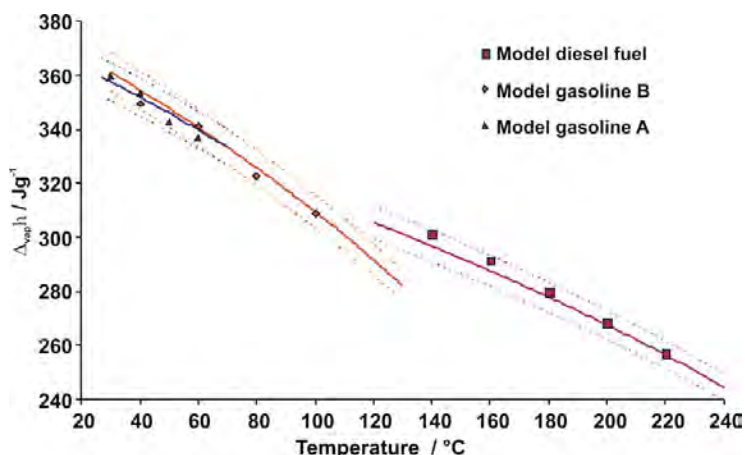

Fig. 4. Measurement results for a model diesel fuel (magenta) and two model gasolines (blue and orange) deviate by less than  $\pm 2\%$  from the calculated values (Watson equation – solid lines).

### Measurement of Solvent Mixtures

To verify the efficiency of this measurement method, specific evaporation enthalpies of various mixtures of n-alkanes were measured as a function of temperature. Since the composition was known, it was possible to calculate the specific evaporation enthalpies of the solvent mixtures using the data of the pure substances. Also in these cases, there was less than a 2% deviation between the calculated and measured values.

### Summary

The measurement method developed, where a solvent volume – preheated to the measuring temperature – was directly injected into the sample crucible of a DSC instrument, delivers the specific evaporation enthalpy of pure substances or solvent mixtures with known compositions.

The measured values deviate by less than 2% from literature data and/or calculated values. The success of the measurement method is due both to the excellent temperature control of the DSC measuring cell for preheating

the sample and maintaining the temperature constant during the measurement, as well as to the precision of the heat flow measurement of the DSC instrument. The accuracy of the measurement technique is limited by the determination of the injected mass.

This method allows easy measurements of the specific evaporation enthalpy of liquids with unknown compositions over a broad temperature range of more than 100 K. The temperature range is limited only by the evaporation rate of the liquid at a defined temperature and the sensitivity of the DSC instrument. In this way, it was possible to determine the specific evaporation enthalpies of gasoline and diesel systems, hydraulic oils, brake fluids and other complex liquid mixtures.

### Contact

Georg-Simon-Ohm University  
of Applied Sciences  
Faculty for Applied Chemistry  
Prinzregentenufer 47  
90489 Nuremberg, Germany  
phone: +(49) 911 5880 1515  
karl-heinz.jacob@ohm-hochschule.de

### The Authors:



From 1980 to 1992, Prof. Dr. Karl-Heinz Jacob studied Technical Chemistry at the Georg-Simon-Ohm University in Nuremberg and Chemistry at the Comprehensive University of Siegen. From 1992 to 1999, he worked at Siemens AG in the field of non-metallic materials. In 1999, he assumed professorship for Physical Chemistry at the Georg-Simon-Ohm University of Applied Sciences in Nuremberg.

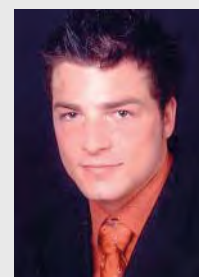

Michael Schuhmann studied Applied Chemistry with a focus on Technical Chemistry at the Georg-Simon-Ohm University of Applied Sciences in Nuremberg. Since 2007, he has been employed by the R&D Department of Huhtamaki Deutschland GmbH & Co.KG, in Forchheim, Germany. After two years as the R&D Manager for the "Hygiene and Healthcare" Division, he now heads the New Markets and Technologies Group.

# PRECISE PRACTICE

## Influences of Heating and Cooling Rates on the DSC Measurement Result

Stephan Knappe, Head of Applications & Services, NGB

Defined heating and cooling rates are important parameters for DSC measurements. International standards recommend a heating rate of 10 K/min or 20 K/min (ISO 11357, DIN 53765, ASTM E 793, ASTM E 794) when striving for thermodynamic equilibrium. In contrast, the objective of quality control and assurance in polymer processing is to obtain meaningful measurement results faster by means of higher heating rates (e.g. 40 K/min). The primary aim is to compare a current measurement on a rejected part sample to a reference sample. The operator dutifully carries out temperature calibration at higher heating rates and records a shift of the melting peak temperature to higher values, but is then often surprised that the DSC measurement on the real polymer sample does not deliver the desired result. The high heating rate causes thermal effects to be displaced; individual peaks or melting phases can no longer be reliably separated.

In figure 1, the relatively high heating rate of 40 K/min for semi-crystalline polybutylene terephthalate (PBT) no longer shows the typical beta melting phase seen in smaller crystallites, but rather only the main melting peak (here at 228°C). If attempting material identification, it could be incorrectly assumed here that the material in question is polyamide 6 (PA 6). The lower heating rate of 10 K/min already shows the beta phase clearly separated from the main peak at 217°C; this is typical for PBT and does not occur for PA6.

Controlled cooling from the melt carried out with an intracooler or liquid nitrogen yields the crystallization behavior of PBT (figure 2). As the cooling rate increases, both the beginning of solidification

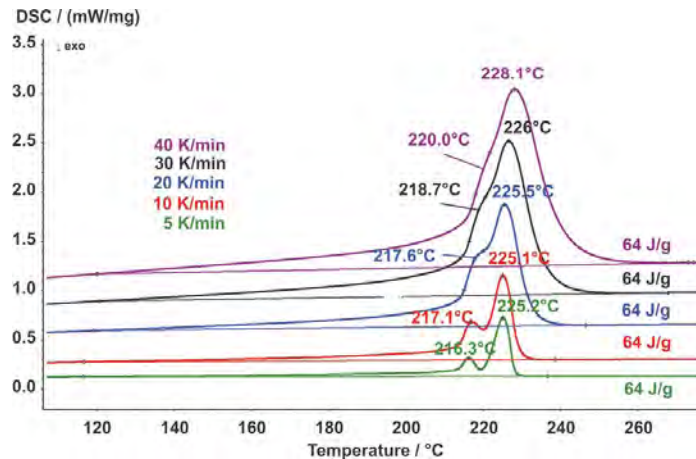

Fig. 1. Influence of the heating rate on the melting behavior of PBT

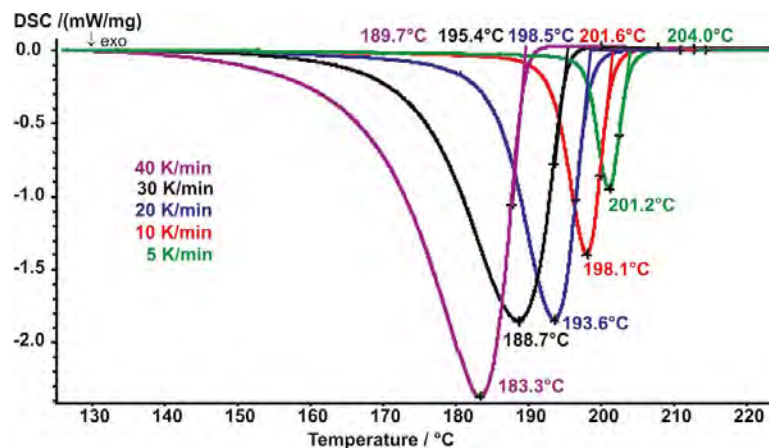

Fig. 2. Influence of the cooling rate on the crystallization behavior of PBT

(extrapolated onset temperature) and the crystallization temperature shift to lower values (figure 3). As the cooling rate increases, the crystallization peak not only gets larger but also extends across a broader temperature range. Although considerably higher cooling rates are employed in injection molding, DSC yields important information as to when or at which temperature the part can be demolded from the tool safely and without danger of distortion.

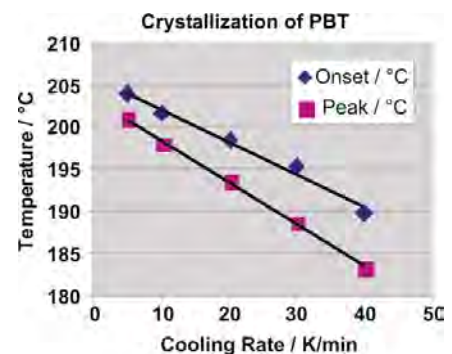

Fig. 3: Correlations of the onset and peak temperatures of PBT with cooling rate

# Faster – Hotter – More Flexible

## The 400 Series Instrument Platform Gets New 2400°C Tungsten and High-Speed Furnaces

Dr. Ekkehard Post, NGB Sales & Applications Support

The idea behind developing the new 400 series instruments, including the STA 449 **F1/F3** and DSC 404 **F1/F3**, was to guarantee outstanding performance and versatility. Prior to the 400 series, NETZSCH had been able to offer highly precise TG-DSC/DTA measurements in the temperature range from -150°C to 1650°C. Now with the new tungsten furnace, the temperature range increases to 2400°C, while the new high-speed furnace allows for extremely fast heating rates of over 1000 K/min from RT to 1250°C.

### Maximum Temperature Tungsten Furnace

The tungsten heating element in the water-cooled 2400°C furnace (fig. 1) guarantees a carbon-free measuring atmosphere – contrary to the widely used graphite furnaces. The furnace is vacuum-tight up to pressures of  $10^{-5}$  mbar. TG or TG-DTA sample carriers – both of W-Re – are available for the measurements. The TG-DTA sample carrier has also been optimized with regard to shorter time constants and higher sensitivity. Measurements can be carried out in either an inert

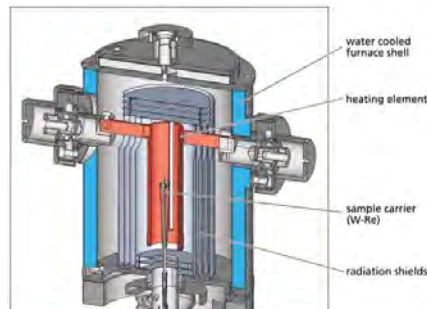

Fig. 1. Cross-section of the tungsten furnace

gas (He, Ar) or high-vacuum atmosphere. Crucibles of W,  $\text{Al}_2\text{O}_3$ ,  $\text{ZrO}_2$  or graphite are available to guarantee optimum crucible-sample combinations depending upon the measurement requirements. The maximum heating and cooling rates are 100 K/min.

The main application of this special furnace is the characterization of metals with high melting points, alloys and ceramics. Shown in figure 3 is a

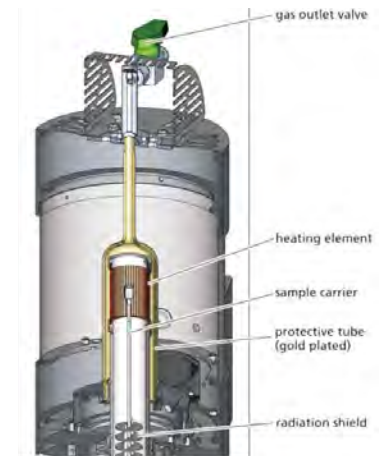

Fig. 2. Cross-section of the high-speed furnace

comparison of the melting behavior of two different cerium oxides measured in a helium atmosphere at 75 K/min. Sample 1 (green curve) shows an additional endothermic DTA peak of approx. 11 J/g prior to the actual melting. In the second sample (blue curve), this “pre-peak” is not visible and melting is also finished approximately 5°C earlier. This indicates differences in quality or the existence of impurities in the first sample.

### High-Speed Furnace

The new high-speed furnace (fig. 2) allows for heating rates of up to 1000 K/min. It can be operated in an atmosphere of either inert gas or air, and covers a temperature range from RT to 1250°C. The fast heating and cooling rates are achieved via the low thermal mass of the Pt heater. With the TG sample carrier, the temperature is measured directly at the sample crucible. This guarantees a precise temperature recording, in contrast with some radiation furnace arrangements.

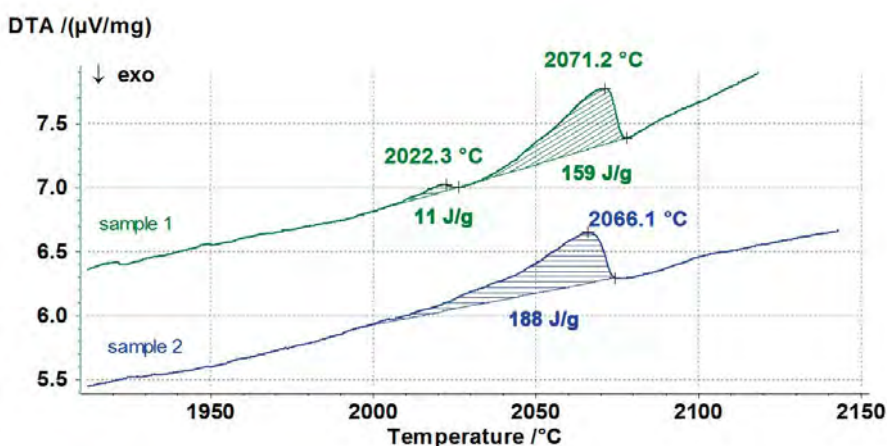

Fig 3. Cerium oxide samples, He 100 ml/min, 75 K/min, W crucibles

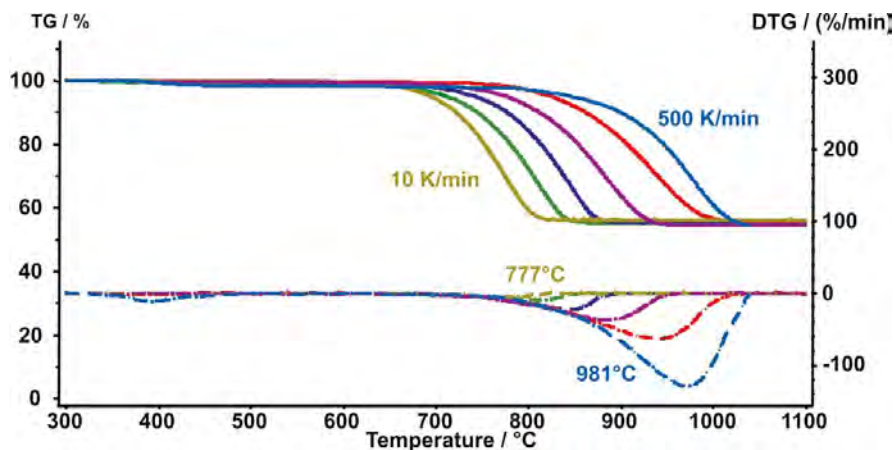

Fig. 4. TG and 1<sup>st</sup> derivatives (DTG) of CaCO<sub>3</sub>, heating rates: 10 K/min to 500 K/min

Sample reactions often depend on the heating rate. In particular, decomposition reactions are shifted to higher temperatures when the heating rate is increased. However, many solid-state reactions also contain a kinetic component, i.e. they are dependent on the heating or cooling rate.

Figure 4 shows the TG and DTG curves of CaCO<sub>3</sub> at different heating rates. When the heating rate is increased from 10 K/min to 500 K/min, the maximum decomposition temperature (DTG peak) is shifted by approximately 200°C.

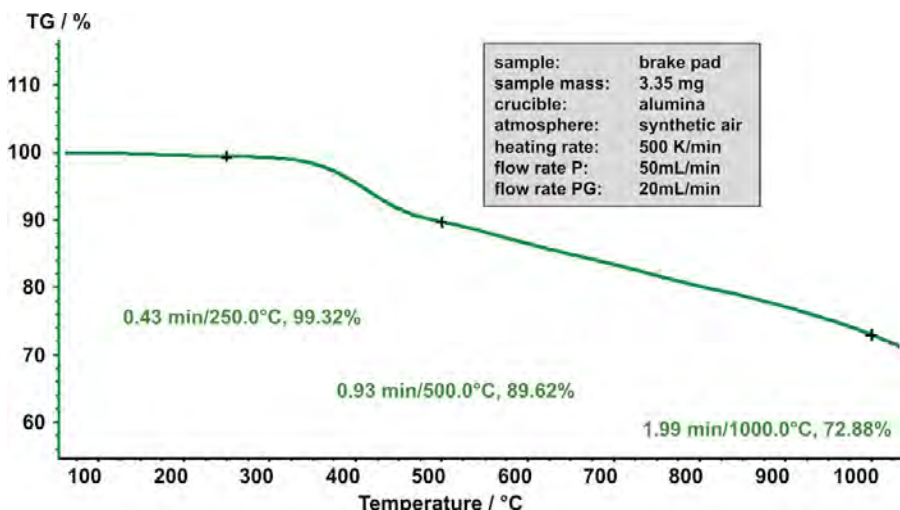

Fig. 5. TG curve of a brake pad, measured at a heating rate of 500 K/min

In figure 5, the thermal stability of a brake pad was investigated in the temperature range from RT to approximately 500 K/min. Among other uses, measurements at such high heating rates can help to simulate real-world situations.



Dr. Ekkehard Post

#### The Author:

Dr. Ekkehard Post studied mineralogy at the Albert-Ludwigs University in Freiburg and completed his doctorate in the field of crystallography. He was member of the scientific staff at the Crystallographic Institute of the same university for several years.

In spring of 1990, he began working in the Applications Laboratory at NETZSCH-Gerätebau GmbH as a specialist for high-temperature instruments such as dilatometers, DSC, STA and mass spectrometer coupling.

From 2003 to 2005, he was head of the Applications Lab at our subsidiary, NETZSCH Instruments Inc. in Burlington, Massachusetts. Since his return to Selb, he has been on the staff of our Sales & Applications Support Department.

Our Events:

[www.netzsch-thermal-analysis.com/en/news/events](http://www.netzsch-thermal-analysis.com/en/news/events)

Event	Date	Location
ECT 2010 8 <sup>th</sup> European Conference on Thermoelectrics	Sept 22 - 24	Como, Italy
LABCompLEX 2010	Sept 28 - Oct 1	Kiev, Ukraine
K 2010	Oct 27 - Nov 3	Düsseldorf, Germany

## Advanced Polymer Testing with NETZSCH Analyzing & Testing



The world's most important trade fair for plastics and rubber – K 2010 – will be taking place from October 27<sup>th</sup> to November 3<sup>rd</sup>, 2010, in Düsseldorf, Germany. Every three years, this trade fair serves as an attractive platform for us to present the NETZSCH Analyzing & Testing portfolio for the polymer sector.

You will find us at Booth E 42 in Hall 10, where we will be displaying

the complete polymer test laboratory with all methods of thermal analysis. Especially noteworthy is our brand new, vacuum-tight TMA 402 **F1 Hyperion**<sup>®</sup> for determination of the thermal expansion coefficient and the glass transition temperature. Force modulation (sinusoidal, rectangular, saw-tooth) additionally allows for measurement of the viscoelastic properties of your polymer sample. At our booth, you will have the chance to take a detailed look at all of the instruments and to discuss your particular questions with our application specialists.

Also, take advantage of the opportunity to attend our free user seminar (in German), focusing on polymer characterization, quality assurance and failure analysis on October 28<sup>th</sup>, in the "CCD South"

wing of the Düsseldorf fairgrounds. Experts from academia and industry will be lecturing about the use of various thermoanalytical measuring techniques in your field. Of course, the latest NETZSCH developments for the polymer sector will also be presented. Take a look at our program:

[www.netzsch-thermal-analysis.com/de/programm\\_seminar-K](http://www.netzsch-thermal-analysis.com/de/programm_seminar-K)

And register via the following link: [www.netzsch-thermal-analysis.com/de/anmeldung\\_seminar\\_K](http://www.netzsch-thermal-analysis.com/de/anmeldung_seminar_K)

We are looking forward to seeing you at the K 2010 – both at our booth and at the user seminar!

Your NETZSCH Team

### Imprint

Editor:  
NETZSCH-Gerätebau GmbH  
Wittelsbacherstraße 42  
95100 Selb, Germany  
Tel.: +49 9287 881-0  
Fax: +49 9287 881-505  
at@netzsch.com  
www.netzsch-thermal-analysis.com

Editorial Staff:  
Dr. Gabriele Kaiser, Dr. Jürgen Blumm,  
Stephan Knappe, Rolf Preuß, Doris Steidl

Layout:  
Dagmar Dittmann

Translation:  
Doris Steidl, Nicole Sachs

Print:  
NETZSCH Werbe- und Service GmbH  
Gebrüder-Netzsch-Straße 19  
95100 Selb  
Germany  
Tel.: +49 9287 75-160  
Fax: +49 9287 75-166  
promotion@netzsch.com

Copyright:  
NETZSCH-Gerätebau GmbH, 09/10