

TA-QMS Coupling

Evolved Gas Analysis



Thermogravimetry and Evolved Gas Analysis

Thermoanalytical techniques are universal tools for characterizing solids and liquids with respect to their thermal behavior. Especially Thermogravimetry finds its broad application for testing the weight changes of the sample during a programmed heat treatment. A multitude of information on material properties, composition and stability is provided. However, the chemical and analytical information about the products causing the weight changes of the sample is often lacking. EGA can supply this additional information.

Decomposition

- Dehydration
- Stability
- Residual Solvent
- Pyrolysis

Solid-gas reactions

- Combustion
- Oxidation
- Corrosion
- Adsorption
- Desorption
- Catalysis

Compositional analysis

- Polymer content
- Proximate analysis
- Binder burn-out
- Dewaxing
- Ash content

Evaporation

- Vapor pressure
- Sublimation

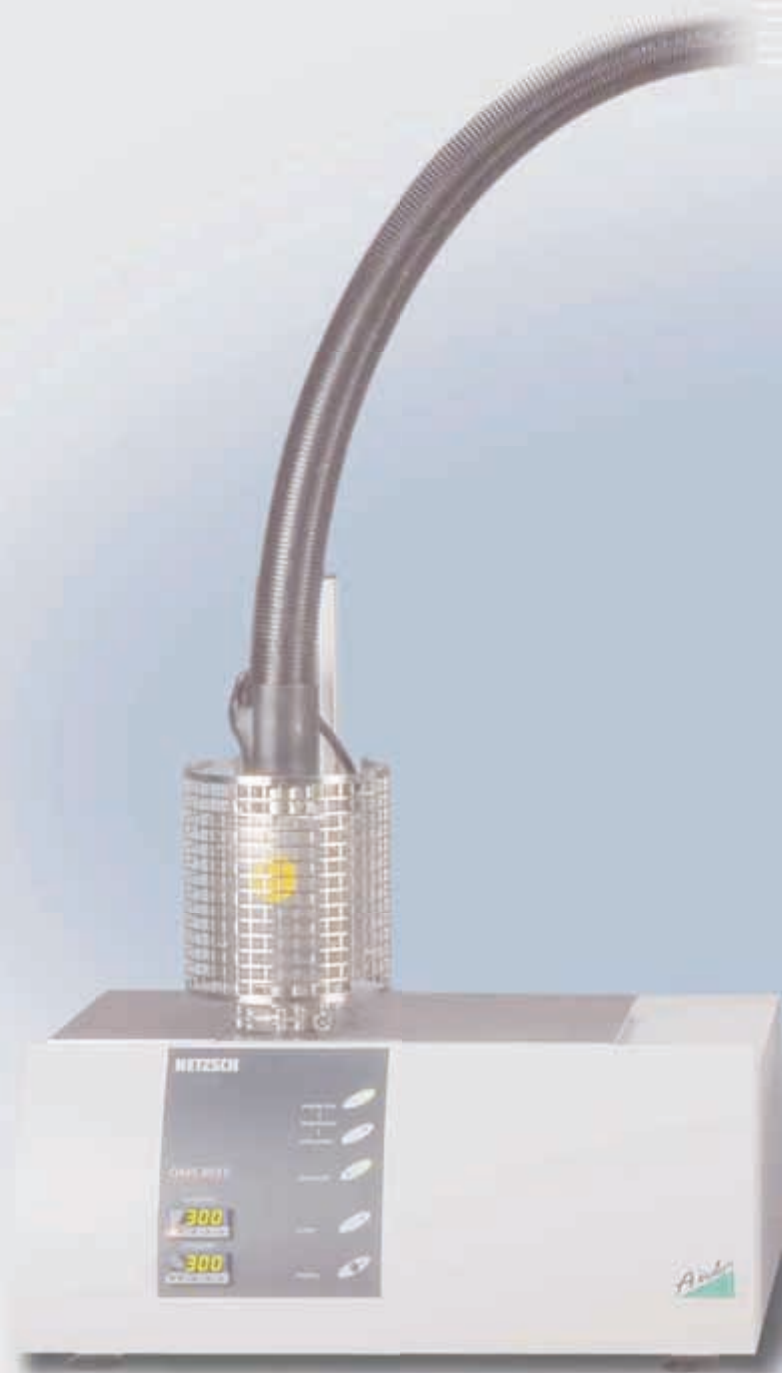

Complementary information

Physical changes detected by thermal analysis are explained by the gas analysis in the mass spectrometer to form a workstation for analytical chemistry. Evolved species are detected down to the ppm level, which exceeds the standard sensitivity of thermal analysis methods. High-class material research and characterization is the result of coupled thermal analysis and mass spectrometry.

Quadrupole Mass Spectrometry (QMS)

The sensitive, selective, fast and continuous function of a quadrupole mass spectrometer makes this system ideally suited for Evolved Gas Analysis in combination with Thermogravimetry. Further key features which help provide an optimal coupling with thermal analyzers include the small dimensions of the quadrupole mass filter, the efficient and reproducible ionization of gases in the electron impact ion source, and the resolution in the detection of molecules, atoms and fragments.

Identification

- Gas composition
- Fingerprint
- Partial pressure
- Fragmentation
- Solid-gas interactions



TA-QMS Coupling

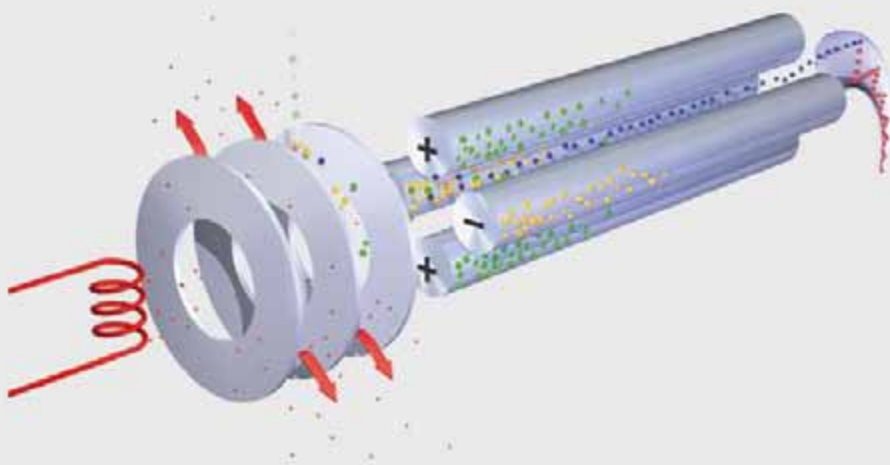

Interface for pressure adjustment

Mass spectrometers, composed of a mass filter, an electron impact ion source and ion detector, work only in high vacuum. Therefore an interface is required for the coupling of a thermobalance, which works with a purge gas flow at atmospheric pressure, to the mass spectrometer. Different versions of pressure reduction interfaces are realized, depending on instrumentation and applications.

Single-step pressure reduction

A capillary of small internal diameter connects the gas outlet at the furnace of the thermobalance with the gas inlet at the mass spectrometer. The pressure continuously drops from atmospheric pressure down to high vacuum in one step.

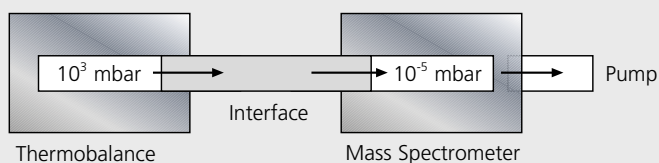

Capillary Coupling

Double-step pressure reduction

Different systems, such as laminar flow capillary, nozzle, and orifice, are used to reduce the pressure in the first step down to the range from 10^{-1} mbar to 10 mbar. A membrane pump, rotary pump or drag stage of the turbo molecular pump is applied to achieve this pressure reduction.

The second step is either an orifice or a skimmer as a molecular leak for the gas inlet into the high vacuum recipient of the mass spectrometer.

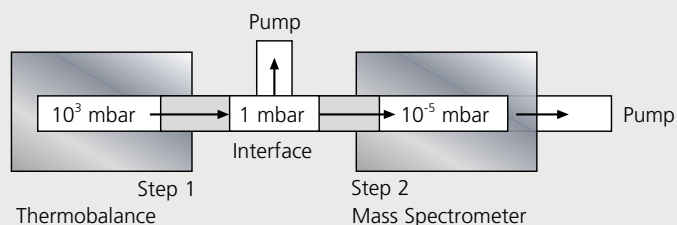

Orifice Coupling Skimmer Coupling

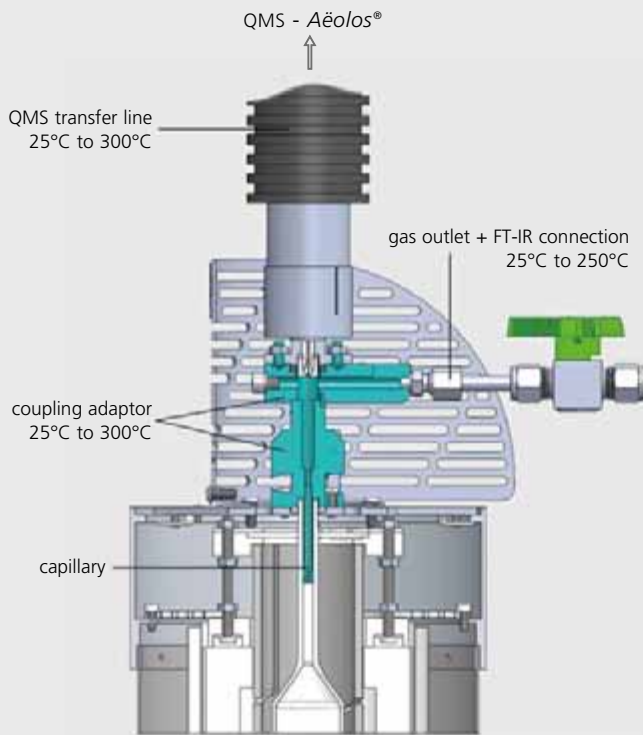

Perfect gas flow conditions

The aim of coupling is to have all relevant gases and vapors transported from the sample area into the ion source of the mass spectrometer for precise qualitative and quantitative analysis. This is only achieved through perfect gas flow conditions in the thermal analyzer, the coupling interface and the gas inlet of the mass spectrometer. As only a small quantity of gas is required for the analysis, a bypass is used at the gas outlet of the thermo-balance for the excess purge gas flow not going through the coupling interface.

Capillary Coupling

Capillary Coupling STA 449 *F1/F3 Jupiter*® / DSC 404 *F1/F3 Pegasus*® / DIL 402 C - QMS described in detail on page 6-7, and simultaneous FTIR coupling
 Capillary Coupling with other adaptor for DSC 204 *F1* and TG 209 *F1* (details on page 6)

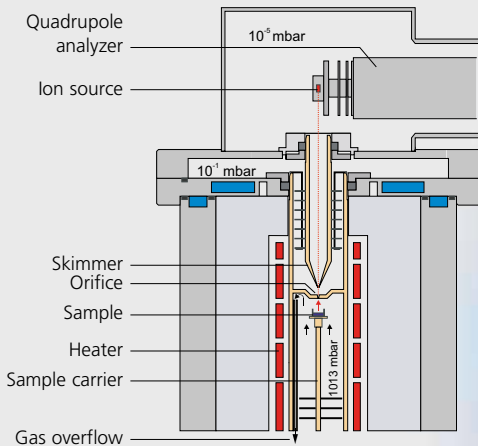

Skimmer Coupling

Skimmer Coupling STA 409 CD - QMS described in detail on page 8-9

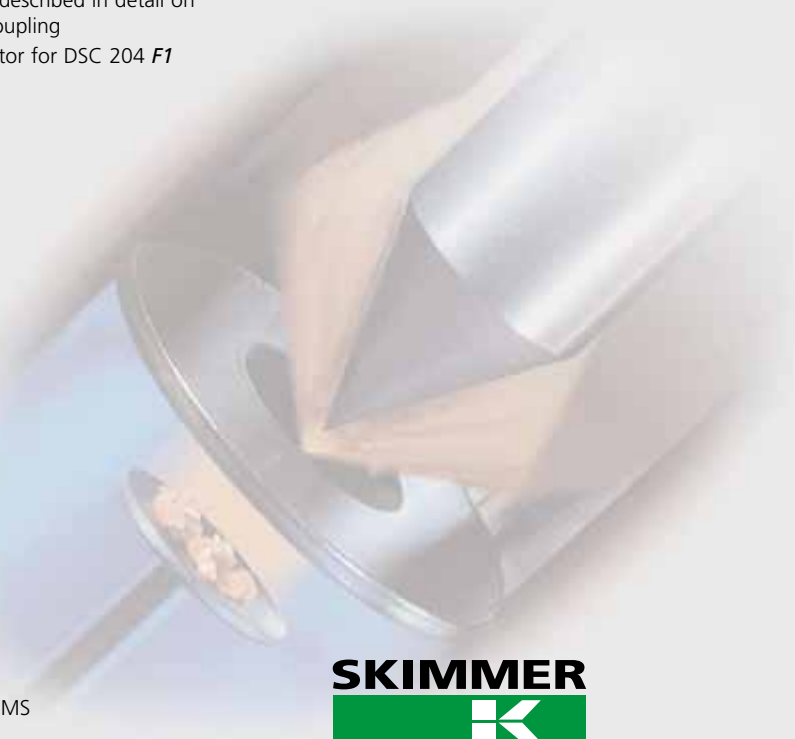

Coupling TA-QMS 403 C *Aëolos*[®]

Top line capillary coupling

A new concept for capillary coupling to NETZSCH thermobalances (TG) and STA instruments (simultaneous TG-DSC) has been realized with the introduction of the QMS 403 C *Aëolos*[®] Quadrupole Mass Spectrometer. Volatile sample materials in a controlled temperature treatment are directly transferred into the electron impact ion source of the MS via a fused silica capillary which can be heated up to 300°C.

The coupling system is improved for:

- Minimized condensation losses through the increased overall temperature of 300°C at the whole gas transfer system from the furnace exit over the capillary to the MS gas inlet.
- Single step pressure reduction to eliminate clogging of orifices.
- Flexibility of the coupling to allow as well standard TG-measurements and also simultaneous TG, MS, (GC-MS), and FTIR measurements.

The QMS 403 C *Aëolos*[®] can also be independently employed for the analysis of other gas sources.



The inert quartz-glass capillary with controlled heating to 300 °C for loss-free gas transfer to the QMS



Heated chamber for easy handling and precise adjustment of the capillary-inlet to the QMS



Quadrupole MS with cathode, electron and ion lenses, mass filter and channeltron detector

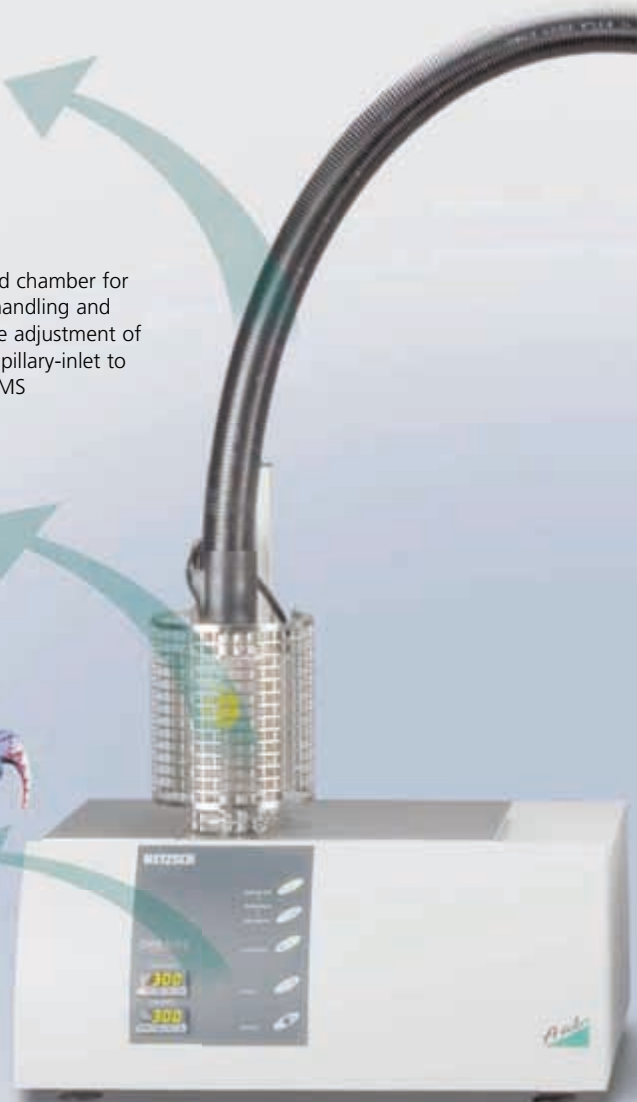

Aëolos[®] specifications:

QMS mass range 300 amu	resolution > 0.5 amu	Scan, Scan-Bargraph, MID
Electron impact ionization	5 eV to 100 eV	2 iridium cathodes
Channeltron SEM	detection limit > 2·10 ⁻¹⁴ mbar	> 1 ppm

Natural vertical gas flow through the STA furnace to the heated adaptor with capillary inlet and bypass

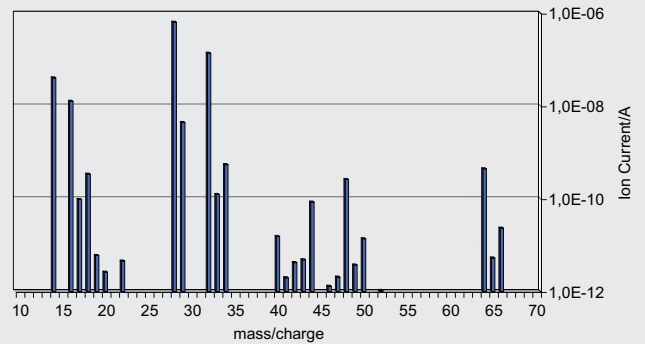

A Scan-Bargraph is often the basis for complete information on all evolved species and allows selection of all or individual interesting mass numbers for import into the *Proteus*® software as continuous MID curves. Here, one scan out of the repeated scans is shown for $\text{Nd}_2(\text{SO}_4)_3 \cdot 5 \text{H}_2\text{O}$ measured in air at 950 °C.

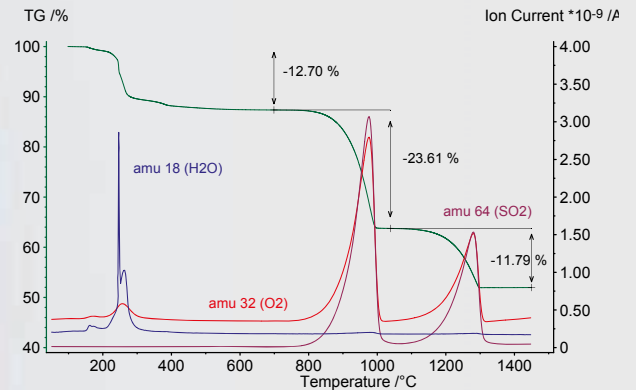

$\text{Nd}_2(\text{SO}_4)_3 \cdot 5 \text{H}_2\text{O}$ (29.53 mg) was heated at a rate of 10 K/min up to 1400 °C in a nitrogen flow. The MID curves, directly imported from the coupled *Aëolos*®, show the well separated gas evolution for water, oxygen and sulfur dioxide in perfect correlation with the TG steps.

TA specifications:

STA 449 *F1 Jupiter*® -150°C to 2000°C
 STA 449 *F3 Jupiter*® -150°C to 2000°C
 DSC 404 *F1 Pegasus*® -150°C to 2000°C
 DSC 404 *F3 Pegasus*® -150°C to 2000°C
 DIL 402 C -180°C to 2000°C
 TG 209 *F1 Iris*® 10°C to 1000°C
 DSC 204 *F1 Phoenix*® -180°C to 700°C

max. 5 g, resolution TG 0.025 µg DSC ≤ 0.1 µW
 max. 35 g, resolution TG 1 µg DSC ≤ 0.1 µW
 resolution DSC ≤ 0.1 µW
 resolution DSC ≤ 0.1 µW
 max. 5000 µm, resolution 1.25 nm, > 0 mm to 50 mm sample dimension
 max. 2 g, resolution TG 0.1 µg
 resolution DSC ≤ 0.1 µW

STA 409 CD with QMS 403/5 *Skimmer* Coupling

Unique supersonic jet gas transfer

The *Skimmer* coupling is the shortest possible solution for the gas transfer from the sample to the QMS. An intense, highly parallel oriented molecular beam is collimated by the aerodynamic beam *Skimmer* from the barrel-shaped jet expansion behind the divergent nozzle. The pressure reduction of the purge gas flow at atmospheric pressure down to the high vacuum behind the *Skimmer* orifice is achieved in two steps along a distance of less than 20 mm. All components are heated to at least the sample temperature and therefore no chance for any condensation exists. Even metal vapors are detected by this unrivaled coupling system.

The nozzle and *Skimmer* are precisely machined from either alumina or amorphous carbon (glassy carbon), allowing application temperatures of 1450°C or 2000°C in the corresponding furnaces. The molecular beams are analyzed by a quadrupole mass spectrometer up to high mass numbers of 512 amu or optionally 1024 amu.

Skimmer coupling specifications:

STA 409 CD
-150°C to 2000°C max. 15 g
resolution TG < 2 µg
DSC < 0.1 µW

QMS range 512/1024 amu
resolution 0.5 amu
Scan, Scan-Bargraph, MID

electron impact ionization
25 eV to 100 eV adjustable
2 tungsten cathodes

off-axis SEM
detection limit > 10⁻¹⁵ mbar
> 100 ppb



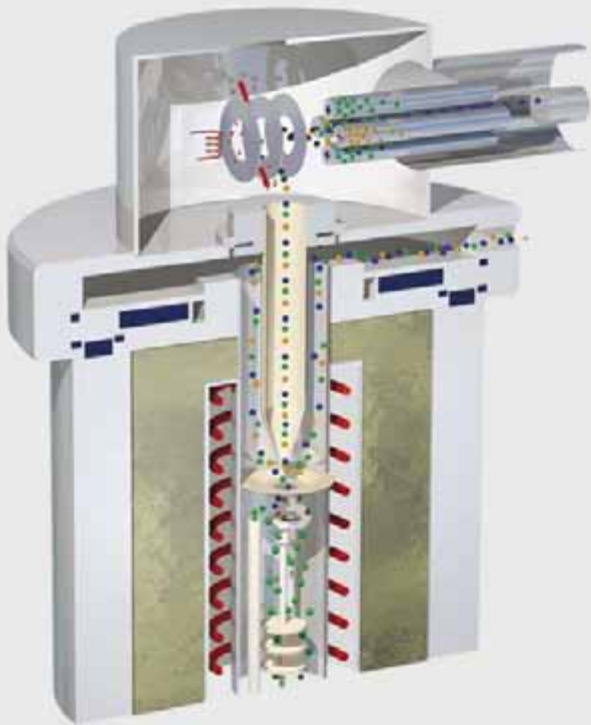

Shortest possible connection between *Skimmer* cone and QMS-ion source with perfect gas flow conditions



Bypass capillary, nozzle and *Skimmer* are heated together with the sample

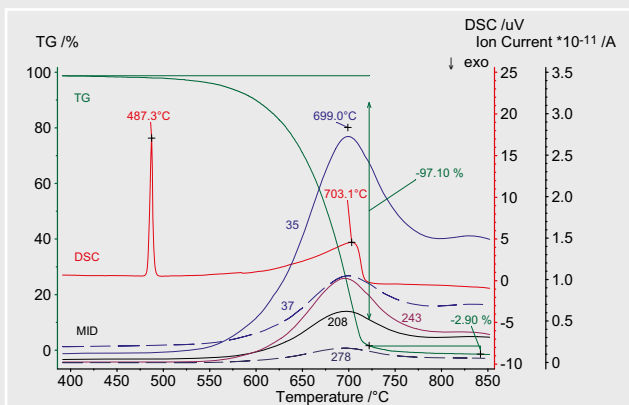

Lead chloride (7.92 mg) in an argon flow of 150 ml/min shows evaporation starting in the melting range (487°C). The molecule ion (PbCl_2 , m/z 278) and fragment ions caused by dissociation and ionization (PbCl m/z = 243, Pb m/z = 208, Cl m/z 37, Cl m/z = 35) are clearly detected far below the boiling temperature of the starting material.

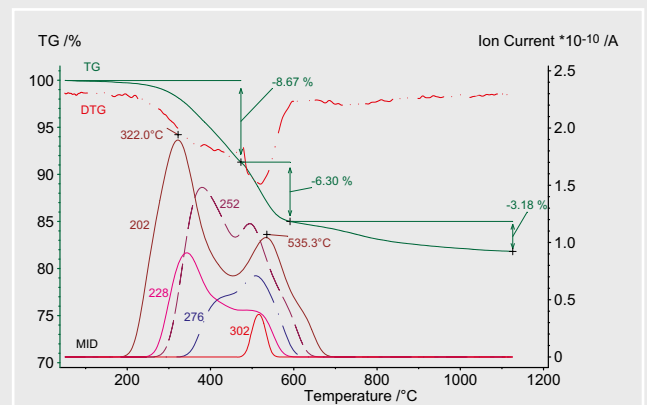

Pitch carbon powder (55.2 mg) decomposes in nitrogen flow (50 ml/min) into aromatic compounds of high molecular weight, mainly up to 600°C. Only selection is shown by MID curves for pyrenes (m/z = 202), Triphenylenes (m/z = 228), Benzo(a)pyrenes (m/z = 252), Benzo(ghi)perylene (m/z = 276) and Dibenzopyrenes (m/z = 302).

Quantitative Gas Analysis

Software

Calibration/quantification

Quantification of the signals from gas analyzers requires a calibration of the whole coupled system with a known type and amount of gas or solvent to control the temperature-dependent flow properties. The unique pulse thermal analysis technique (*PulseTA*[®]) is a perfect tool to achieve quantitative gas detection in separate calibration runs or even online during a sample measurement. A known amount of gas is injected into the sample gas stream and the registered signal of the resulting pulse is integrated.

The application of *PulseTA*[®] also increases the sensitivity of thermoanalytical measurements, allows studying gas solid reactions with stepwise control of the process by the pulsed supply of the reactive gas, and simplifies adsorption/desorption experiments.

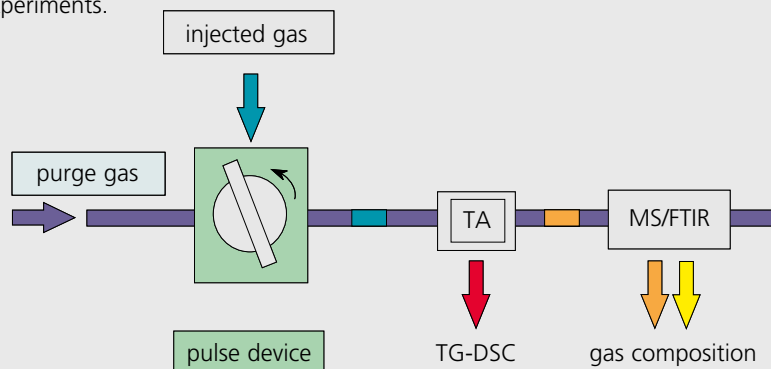

Thermal decomposition of $\text{ZnC}_2\text{O}_4 \cdot 2\text{H}_2\text{O}$ in a helium gas flow (50 ml/min).

With corresponding pulses of CO and CO_2 , marked by P, a quantification of the evolved gases is possible, even with the overlapping contributions to m/z 28 by CO and the fragmentation of CO_2 . The reaction between CO_2 and traces of water is shown by the H_2 signal and quantified by the H_2 pulse P.

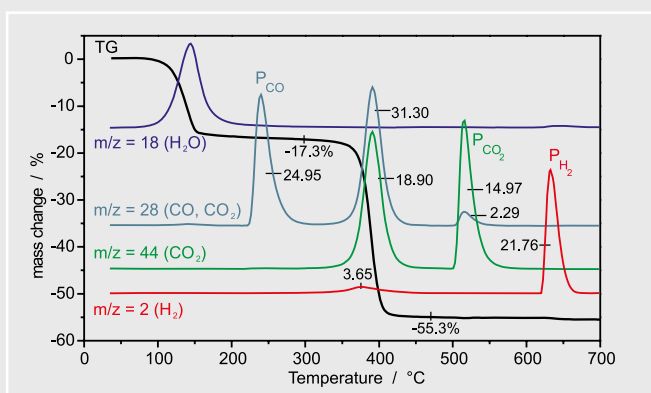

Determination of carbon and sulfur content in a petrol rock. During calcination in air, the CO_2 and SO_2 signals can be exactly quantified through corresponding pulses, even with the contribution of water to the detected weight loss.

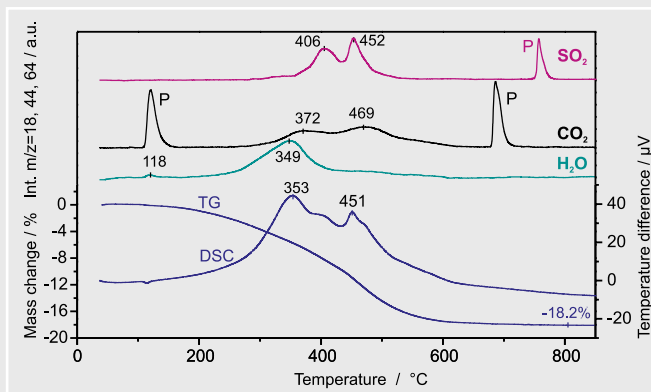

Fully Integrated TA-MS Software

The control of measurements with coupled TG-QMS instruments is governed by the *Proteus*[®] software. The user gives the command for data acquisition once both the QMS and the *Proteus*[®] software are ready with parameter inputs and checking of pressure and ion source conditions. The online data collection is simultaneous and synchronized through triggered start to guarantee a precise time and temperature correlation between all the

signals from the two coupled analytical systems during evaluation. The user works with the two software packages on one computer and has all possibilities to evaluate data and display results in the *Proteus*[®] software according to his preferences.

The integration of the TA and QMS software based on effective data exchange from acquisition to evaluation makes the coupled TG-QMS a real functional unity.

Fast parameter input for routine experiments:

- fast MID input of 8 mass numbers
- fast mass range input for scan-bargraphs

Versatile programming for research work:

- selection of 64 MID mass numbers
- selection of analogue scans in max. 64 channels
- selection of scan-bargraphs with optimized rate and sensitivity

Sample temperature acquisition together with MS data

Common evaluation in *Proteus*[®] software:

- TG-DSC/DTA-MID curves: characteristic temperatures, peak areas
- TG-DSC/DTA-scan-bargraph envelope curves: characteristic temperatures, peak areas
- TG-DSC/DTA Total Ion Current
- Evaluation of MS spectra
- Export of MS data in NIST-library compatible format

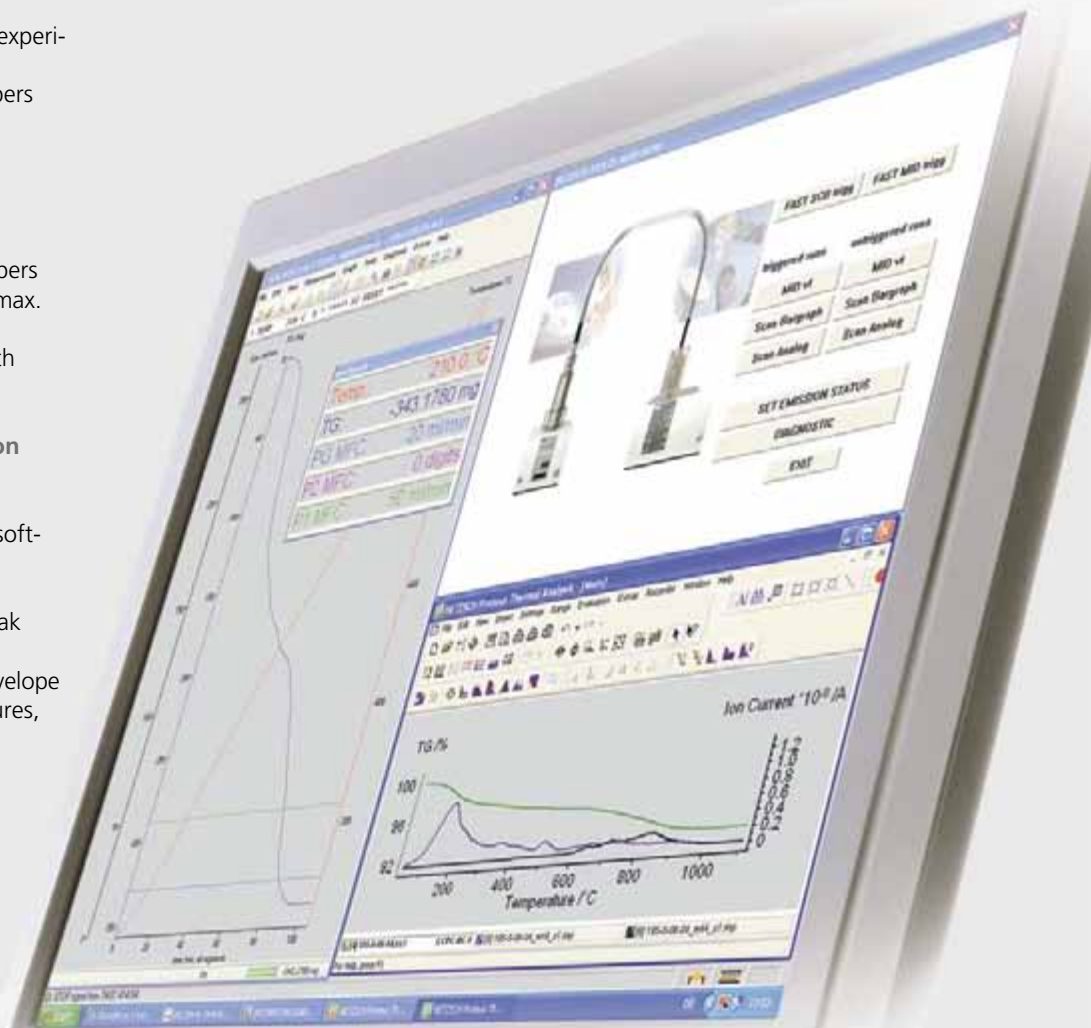

Global Customer Support & Service Network

NETZSCH-certified personnel at 45 service centers across the globe provide fast and reliable customer support including qualified installation, calibration services, and preventive maintenance. In addition, our applications laboratories offer contract testing and support to address even the most specific of thermal analysis issues.

Leading Thermal Analysis.

When it comes to Thermal Analysis, Adiabatic Reaction Calorimetry and the determination of Thermophysical Properties, NETZSCH leaves no stone unturned. Our 50 years of applications experience, broad state-of-the-art product line and comprehensive service offerings ensure that our solutions will not only meet your every requirement but also exceed your every expectation.

NETZSCH-Gerätebau GmbH
Wittelsbacherstraße 42
95100 Selb
Deutschland
Tel.: +49 9287 881-0
Fax: +49 9287 881-505
at@netsch.com

www.netsch.com